



WEST BENGAL STATE UNIVERSITY
B.Sc. Honours 4th Semester Examination, 2020

PHSACOR10T-PHYSICS (CC10)

Time Allotted: 2 Hours

Full Marks: 40

*The figures in the margin indicate full marks.
Candidates should answer in their own words and adhere to the word limit as practicable.
All symbols are of usual significance.*

Question No. 1 is compulsory and answer any two from the rest

1. Answer any **ten** questions from the following: 2×10 = 20
- How the slew rate of an OPAMP is related to the maximum operating frequency of an OPAMP?
 - Distinguish between Zener breakdown and avalanche breakdown.
 - Draw the circuit diagram of an emitter follower and state one of its use.
 - Draw the energy band diagrams for intrinsic and *p*-type semiconductors.
 - What is the Barkhausen criterion for a feedback amplifier to function as an oscillator?
 - A differential amplifier has difference mode gain $A_d = 5000$ and CMRR = 1000. Find the output voltage for inputs $v_1 = 200 \mu\text{V}$ and $v_2 = 190 \mu\text{V}$.
 - What are the fundamental differences between class A and class C amplifiers?
 - Establish $\mu = r_p \times g_m$ for a JFET.
 - Find the bandwidth of an inverting OPAMP with $R_1 = 1 \text{ k}\Omega$, $R_2 = 15 \text{ k}\Omega$. Assume that the unity gain bandwidth of the OPAMP is 3.
 - Draw a circuit diagram of a D/A converter using R-2R.
 - Establish the relation $I_C = (1 + \beta)I_{CBO} + \beta I_B$ for a BJT.
 - Write down the approximate drops of voltages across an LED and a Si-diode respectively when they are forward biased at room temperature.
 - A capacitor of $0.1 \mu\text{F}$ is charged to 10 V and then discharged through a resistance $1 \text{ M}\Omega$. Calculate time required by the capacitor to reach 5 V.
 - Two capacitors $1 \mu\text{F}$ and $9 \mu\text{F}$ are connected in series with a 10 V AC source. Calculate the voltage drops across the respective capacitors.

- 2. (a) Write down the relation among barrier potential, doping concentrations and intrinsic carrier concentration for a *p-n* junction diode. Explain the statement: “The barrier potential across a *p-n* junction diode cannot be measured directly by connecting a voltmeter across the *p-n* junction.” 1+2
- (b) What do you mean by load line and the Q-point of a semiconductor diode circuit? Explain with suitable diagram. 2+1
- (c) Draw a circuit diagram of a full wave bridge rectifier using semiconductor diodes. Why one should prefer a bridge rectifier over a full wave rectifier using centre tap transformer? 2+2
- 3. (a) A phase shift oscillator uses OPAMP as amplifying element. Find the capacitance of the capacitor used in the RC network employed in the oscillator, if the frequency of oscillation is 10 kHz and $R = 100\text{ k}\Omega$. 3
- (b) Design a non-inverting amplifier of gain 5 using an ideal OPAMP. Draw the necessary circuit diagram. 2+1
- (c) Draw the circuit diagram of a Wien-bridge oscillator with output frequency 500 Hz, choosing suitable circuit elements and identify the feedback mechanisms in this case. 2+2
- 4. (a) Draw the output characteristics of an *n-p-n* transistor in CE and CC modes respectively, labelling different regions of operations. 3+3
- (b) What is JFET? An *n*-channel Si (having dielectric constant 12) JFET with a channel width 0.06 cm is doped with a concentration $N_d = 10^{21}\text{ m}^{-3}$. Find the pinch off voltage. 1+3
- 5. (a) Given $I_{CQ} = 2\text{ mA}$ and $V_{CEQ} = 10\text{ V}$, determine R_1 and R_C for the *n-p-n* transistor circuit given below: 2+2

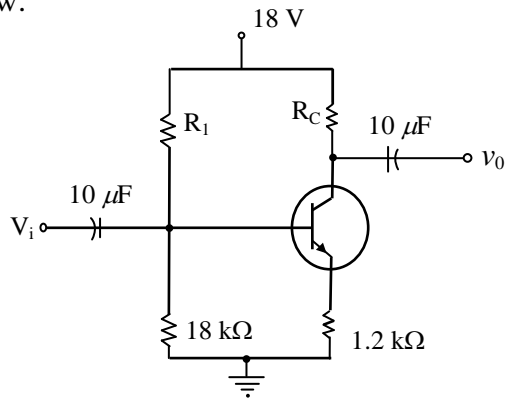

- (b) Draw a labelled circuit diagram of a two stage R-C coupled amplifier. Find the mid frequency gain of the amplifier with the help of an ac equivalent circuit. Explain why gain falls at high frequencies. 1+3+2

N.B. : Students have to complete submission of their Answer Scripts through E-mail / Whatsapp to their own respective colleges on the same day / date of examination within 1 hour after end of exam. University / College authorities will not be held responsible for wrong submission (at in proper address). Students are strongly advised not to submit multiple copies of the same answer script.

—x—